



## Technical Data Sheet

# STANDARD CONFIGURATION --

## TDS0289 – *mtu* Kinetic PowerPack Single

<b>Voltage/Frequency</b>	480V / 60Hz
<b>Rated Power</b>	2000 kVA at $\cos \phi = 0.8$
<b>Critical Power</b>	2000 kVA
<b>Diesel Engine</b>	MTU 16V4000G74S FO
<b>Revision</b>	05

## Table of contents

1	SYSTEM GENERAL SPECIFICATIONS.....	4
1.1	Ratings .....	4
1.2	Key dimensions and weight of the mtu Kinetic PowerPack .....	4
1.3	Normal service conditions .....	4
1.4	Air flow requirements .....	4
1.5	Noise levels in conditioning mode (measured at 1 meter) .....	5
1.6	Engine noise levels (measured at 1 meter) .....	5
1.7	Exhaust noise levels (measured at 1 meter).....	5
1.8	Noise levels in independent mode (measured at 1 meter).....	5
1.9	Vibrations.....	5
1.10	Power module colours.....	5
1.11	Special features.....	5
2	DIESEL ENGINE.....	6
2.1	Main features .....	6
2.2	Special features and auxiliaries.....	6
2.3	Fluids capacities .....	7
2.4	Fuel.....	7
2.5	Exhaust.....	7
2.6	Radiator .....	8
2.7	Electric starting system.....	8
3	ELECTROMAGNETIC CLUTCH .....	9
4	STATO-ALTERNATOR .....	10
5	POWER PANEL.....	11
5.1	Dimensions and weight .....	11
5.2	Choke .....	12
5.3	Circuit breakers .....	12
6	AUXILIARY PANEL (One per unit).....	13
6.1	Dimensions and weight .....	13
7	CONTROL PANEL.....	14
7.1	Dimensions and weight .....	14
7.2	HMI touch screen.....	15
7.3	Built in features.....	16
7.4	Communication bus length.....	16
8	SINGLE LINE DIAGRAM.....	17
9	ELECTRICAL PERFORMANCES.....	18
9.1	Acceptable mains tolerance in conditioning mode .....	18
9.2	Voltage regulation (conditioning and independent mode) .....	18

9.3	Frequency regulation in independent mode .....	18
9.4	Harmonics .....	18
9.5	Phase angle .....	18

NOTES:

- Information is given for guidance only and is subject to adjustment at the final design stage.
- Pictures are not contractual.

## 1 SYSTEM GENERAL SPECIFICATIONS

### 1.1 Ratings

Characteristics	Value	Unit	Remark
Rated critical power	2000	kVA	at $\cos \phi = 0.8$
Overload in conditioning and independent modes	10	%	of rated critical power
Maximum load step	100	%	of rated critical power
Efficiency	95.2	%	In conditioning mode, including choke losses

### 1.2 Key dimensions and weight of the mtu Kinetic PowerPack

See drawing 37376.

### 1.3 Normal service conditions

Min./Max. temperature	Min./Max. relative humidity	Maximum altitude	Air quality
-25°C / 40°C	20 / 90 % non condensing	400 m a.s.l.	No dust or sand loaded air

Except if otherwise stated, all values of this data sheet are given for above environmental conditions. For conditions out of these limits, please consult with us: air-conditioned power and control panels are available, filters can be added for application in dusty/sandy environments... For more details on air quality, refer to document TI0047 – Environmental conditions. For storage/transport conditions please consult with us.

### 1.4 Air flow requirements

Working mode	Air purpose	Value	Unit
Conditioning mode	Ventilation	29800	m <sup>3</sup> /h
	Combustion	11200	m <sup>3</sup> /h
Option 1: Remote radiator with electrically driven fans			
	Cooling	77100	m <sup>3</sup> /h
	TOTAL	88300	m <sup>3</sup> /h
Option 2: Free-standing radiator with electrically driven fans			
	Cooling	Min 127600	m <sup>3</sup> /h
	TOTAL	As per selected cooler	m <sup>3</sup> /h

### 1.5 Noise levels in conditioning mode (measured at 1 meter)

Freq. (Hz)	63	125	250	500	1000	2000	4000	8000	Global
Pressure	91dB	96dB	102dB	103dB	103dB	95dB	92dB	80dB	106dB(A)

### 1.6 Engine noise levels (measured at 1 meter)

Freq. (Hz)	63	125	250	500	1000	2000	4000	8000	Global
Pressure	75dB	93dB	94dB	98dB	99dB	99dB	95dB	105dB	107dB(A)

### 1.7 Exhaust noise levels (measured at 1 meter)

Freq. (Hz)	63	125	250	500	1000	2000	4000	8000	Global
Pressure	109dB	117dB	118dB	116dB	109dB	107dB	98dB	78dB	117dB(A)

### 1.8 Noise levels in independent mode (measured at 1 meter)

Freq. (Hz)	63	125	250	500	1000	2000	4000	8000	Global
Pressure	91dB	98dB	103dB	104dB	104dB	100dB	97dB	105dB	109dB(A)

### 1.9 Vibrations

More than 96% of the vibrations are eliminated by vibrations dampers inserted between an intermediate frame and the main frame, thus allowing the power module to be laid directly on the ground.

### 1.10 Power module colours

Engine	Stato-Alternator	Frame
RAL 7001 (Silver grey)	RAL 9010 (Pure white)	RAL 5002 (Ultramarine blue)

### 1.11 Special features

Accessories	Included
Vibration monitoring – Stato-Alternator	No
Bearings automatic greasing (AGB)	No
Electrical measurements real-time recording	No
Engine automatic lubricant refill	No

## 2 DIESEL ENGINE

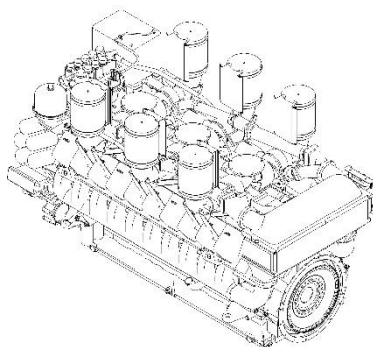

### 2.1 Main features

Characteristic	Value	Unit	Remark
Brand	MTU		
Model	16V4000G74S FO		
Rated speed	1800	RPM	
Displacement	76.3	l	
Number of cylinders	16		
Electrical system	24	V DC	
Prime power (PRP)	-	kW	At 25°C and 100kPa according to ISO 3046
Standby power (ESP)	2280	kW	

### 2.2 Special features and auxiliaries

Accessories	Included
Prelubrication pump	Yes
Manual oil sump extraction pump	Yes
Water circuit preheating with thermostatic control and circulation pump	Yes
Air/water charge air cooler	Yes
Oil pressure electrical sensor	Yes
Water temperature electrical sensor	Yes
Overspeed electrical sensor	Yes
Fuel cooler	Yes

## 2.3 Fluids capacities

Fluid type	Quantity	Unit
Lubricating oil capacity (total)	300	l
Lubricating oil consumption at rated power	NA	l/h
Coolant capacity in engine circuit (radiator not included)	175	l
Coolant capacity in aftercooler circuit (if applicable and radiator not included)	50	l

## 2.4 Fuel

Fuel consumption (Admissible tolerance: +/-5%) at 100% ESP	g/kWh	l/h
at 100% ESP	202	542
at 25% rated output power	247	129
at 50% rated output power	223	233
at 75% rated output power	206	324
at rated output power	200	420

Other characteristics	Value	Unit
Fuel maximum inlet temperature	55	°C
Maximum fuel flow	1200	l/h

## 2.5 Exhaust

Characteristics	Value	Unit
Exhaust gas flow	27400	m <sup>3</sup> /h
Exhaust gas temperature	465	°C
Heat rejection to exhaust	NA	kW
Exhaust back pressure (Design value)	30	mbar
Maximum exhaust back pressure	85	mbar

Exhaust emissions (ESP)	Value	Unit
Complies with	-	
NO <sub>x</sub>	6000	mg/m <sup>3</sup>
CO	300	mg/m <sup>3</sup>
Unburned hydrocarbons	150	mg/m <sup>3</sup>
Particulate matter (Dust)	50	mg/m <sup>3</sup>

## 2.6 Radiator

Characteristics	Value	Unit
Maximum air temperature at radiator outlet	< 85	°C
Maximum total power consumption of the fans (*)	70	kW
Heat rejection, engine cooling circuit	950	kW
Heat rejection, aftercooler circuit	560	kW
Max. static head of coolant above engine	15	m
<b>Engine circuit</b>		
Max. pressure drop external to engine	70	kPa
Coolant flow rate	81	m <sup>3</sup> /h
Coolant temperature FROM engine	95	°C
<b>Aftercooler circuit</b>		
Max. pressure drop external to engine	70	kPa
Coolant flow rate	35.5	m <sup>3</sup> /h
Coolant temperature TO aftercooler	70	°C
<b>Option 1: Remote radiator with electrically driven fans</b>		
Static pressure reserve	-	Pa
Radiator air inlet temperature	40	°C
<b>Option 2: Free-standing radiator with electrically driven fans</b>		
Static pressure reserve	As per selected cooler	Pa
Radiator air inlet temperature	45	°C

(\*) If a remote radiator is used, this value includes the power of both the radiator fans and the power module cooling fans in independent mode. Please consult with us for proper selection and dimensioning of remote radiator.

## 2.7 Electric starting system

Qty of starters	System voltage	Type of batteries	Total Cold Crank Amps @ 24VDC	
			CCA DIN -18°C	CCA EN -18°C
2	24 V	Maintenance free, lead acid	3200A	5120 A

### NOTES:

- 12VDC batteries are connected in series by pairs to obtain 24VDC.
- The required number of pairs of batteries is derived out of the Total CCA divided by the respective CCA (DIN or EN) of one battery, rounded up to a multiple of the quantity of starters.

### 3 ELECTROMAGNETIC CLUTCH

Characteristics	Value	Unit
Brand	Stromag	
Model	MEA-A 1000	
Features	Brushless, ringless, lubrication and maintenance free	
Excitation	24	V DC
Coupling	Rubber type	
Housing	PI-560/1000/00/21R	

## 4 STATO-ALTERNATOR

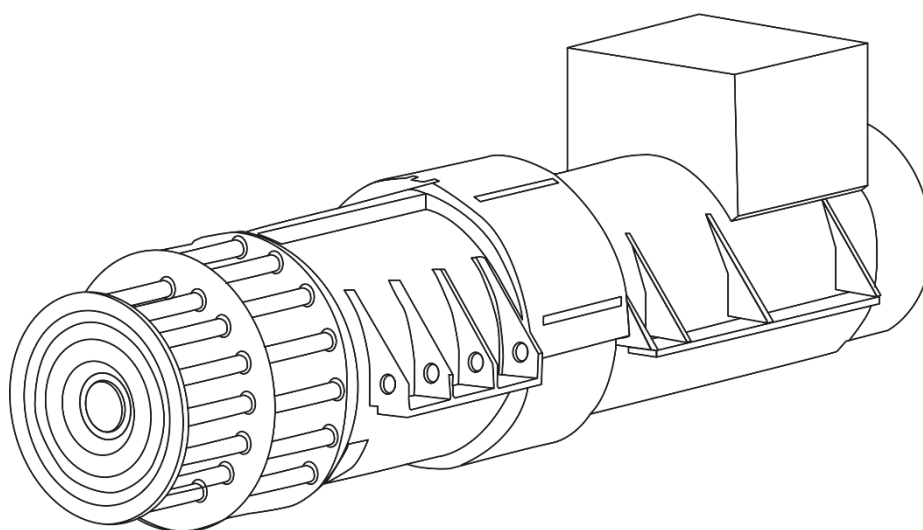

Characteristic	Value	Unit	Remark
Brand	RRSL		
Model	KS5-560N-2J-AX		
In accordance with	IEC standards		
Rotating speed (inner/outer rotor)	1800/3000	RPM	
Rated frequency	60	Hz	
Voltage	480	V AC	
Power factor	0.8		Lagging
Rated current (In)	2406	A	
Continuous output power	2000	kVA	
Max. capacitive reactive power	590	kVAr	
Insulation temperature class	Class H		
Operation to class	Class F		
Protection degree	IP23		
Short circuit current to upstream	3	In	From KP only
Short circuit current to downstream	14	In	From KP only

## 5 POWER PANEL

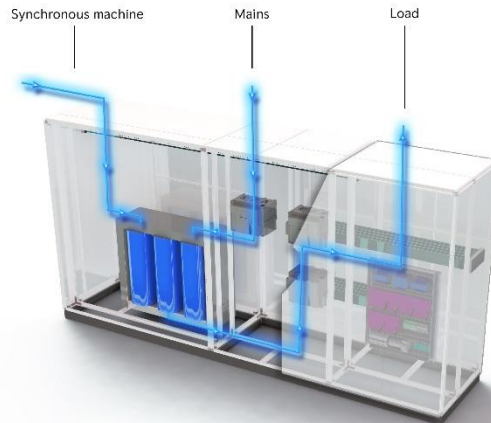

Characteristics	Value	Unit
Earthing system	TNS	
Internal separations form	3B	
Rated short-time withstand current (I <sub>cw</sub> )	50	kA/1sec
Min. operating ambient temperature	5	°C
Max. operating ambient temperature (*)	40	°C
Complies with	IEC standards	
Protection degree	IP32	
Standard colour	RAL 7035 (Light grey)	

(\*) Average over 24h not to exceed 35°C.

### 5.1 Dimensions and weight

Characteristics	Value	Unit
Width	4656	mm
Depth	1200	mm
Overall height	2350	mm
Weight	5500	kg

#### NOTES:

- Dimensions and weight are estimates and must be confirmed after detailed design phase.
- Provide approximately 10 cm above panel top to allow ventilation air to escape freely.
- Cable entry possible from top, bottom, left or right. To be specified when ordering.

## 5.2 Choke

Characteristics	Value	Unit
Inductance type	Three-phase, with five-limb core	

## 5.3 Circuit breakers

#	Circuit breaker	Rating (A)	Number of poles	Fixed / Withdrawable	Rated breaking capacity (Ics)
1	Remotely controlled CB QD1 - UPSTREAM	3200	3	Withdrawable	65kA
1	Remotely controlled CB QD2 - DOWNSTREAM	3200	3	Withdrawable	
1	Remotely controlled switch QD3 - AUTOMATIC BYPASS	3200	3	Withdrawable	

### NOTES:

- RRSLS scope of supply is limited to breakers QD1, QD2, QD3. The other breakers (for instance QDA, QDB, QMB...) are by others.
- Breakers are not accessible from the front of the panel.

## 6 AUXILIARY PANEL (One per unit)

The AXL panel is intended to distribute AC voltages to the auxiliaries (radiator, fuel pump, etc). The continuous availability of these voltages is critical for the good operation of the **mtu** Kinetic PowerPack installation, which is why it is supplied from the downstream bus of the Power Panel.

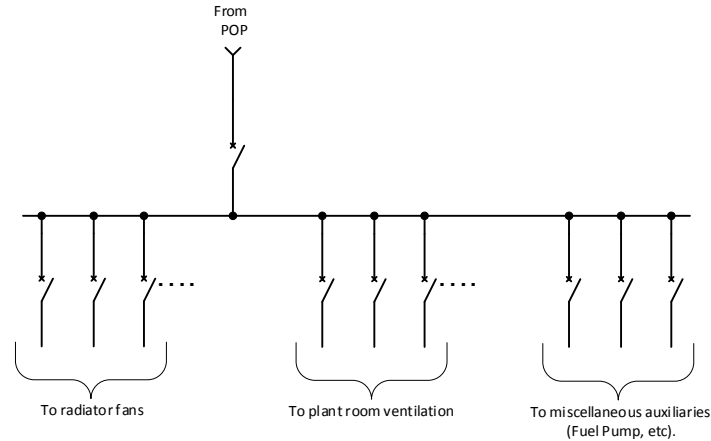

Characteristics	Value	Unit
Min operating ambient temperature	5	°C
Max operating ambient temperature (*)	40	°C
Complies with	IEC standards	
Protection degree	IP43	
Standard colour	RAL 7035 (Light grey)	

(\*) Average over 24h not to exceed 35°C

### 6.1 Dimensions and weight

Characteristics	Value	Unit
Width	1200	mm
Depth	500	mm
Overall height	2210	mm
Weight	500	kg

#### NOTES:

- Dimensions and weight are estimates and must be confirmed after detailed design phase.
- Provide approximately 10 cm above panel top to allow ventilation air to escape freely.
- Cable entry possible from top.



## 7.2 HMI touch screen

The HMI touch screen located on the front door provides access to:

- Measurements (voltage, frequency, power factor, temperature...)
- Controls (secure load, by-pass, engine test, mains fault test...)
- Status (alarms, maintenance, position of breakers...)
- Language selection (integrated languages: EN, FR, DE, ES, NL...)
- Settings (clock, scheduling of maintenance and system tests...)

The following screens give some examples of these functionalities.

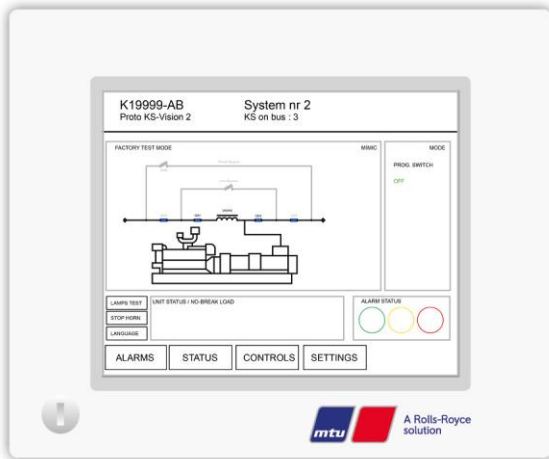

HMI Main Screen

General information and access to other screens.

### HMI Electrical Measurements

Displays all needed electrical measurements like voltage, current, power factor...

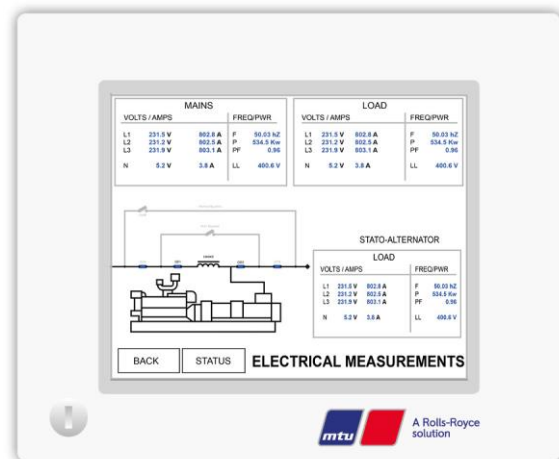

HMI KP Measurements

Displays mechanical information like fuel tank level or bearings temperatures.

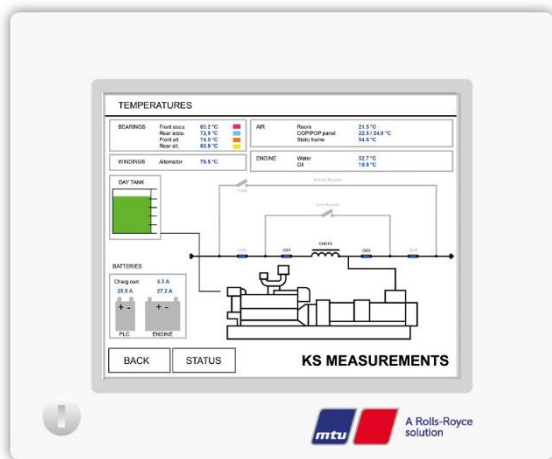

### 7.3 Built in features

The following features/components are part of the KS-VISION® system and are integrated in the Control Panel:

- Digital Control Module (DCM) is responsible for the real-time control which includes:
  - Accu inner and outer rotor speed regulation
  - Voltage regulation
  - Mains failure detection
  - Synchronizer control
  - ...
- SAIA Programmable Logic Controller (PLC)
- Communication means:
  - Remote supervision over Ethernet (Modbus TCP/IP available as an option)
  - Digital I/O's
- Accu maintenance braking
- Energy storage and recovery checks
- Engine speed control and regulation
- Emergency stop
- ...

### 7.4 Communication bus length

Two communication protocols are used: Profinet (PLC) and Canbus (DCM and rEDBus). The communication buses must have the following characteristics:

- Ethernet:
  1. Cat6 or better
  2. Individual and overall shield (S/FTP or equivalent)
  3. Maximum cable length (point to point): 100m
- Canbus:
  1. Canbus certified cable
  2. Maximum bus length: 400m
  3. Characteristic impedance: 120  $\Omega$  at 1MHz
  4. Section: 0.75 mm<sup>2</sup> (18 AWG)

With bus length being defined as the length of cable between the first and last equipment communicating.

## 8 SINGLE LINE DIAGRAM

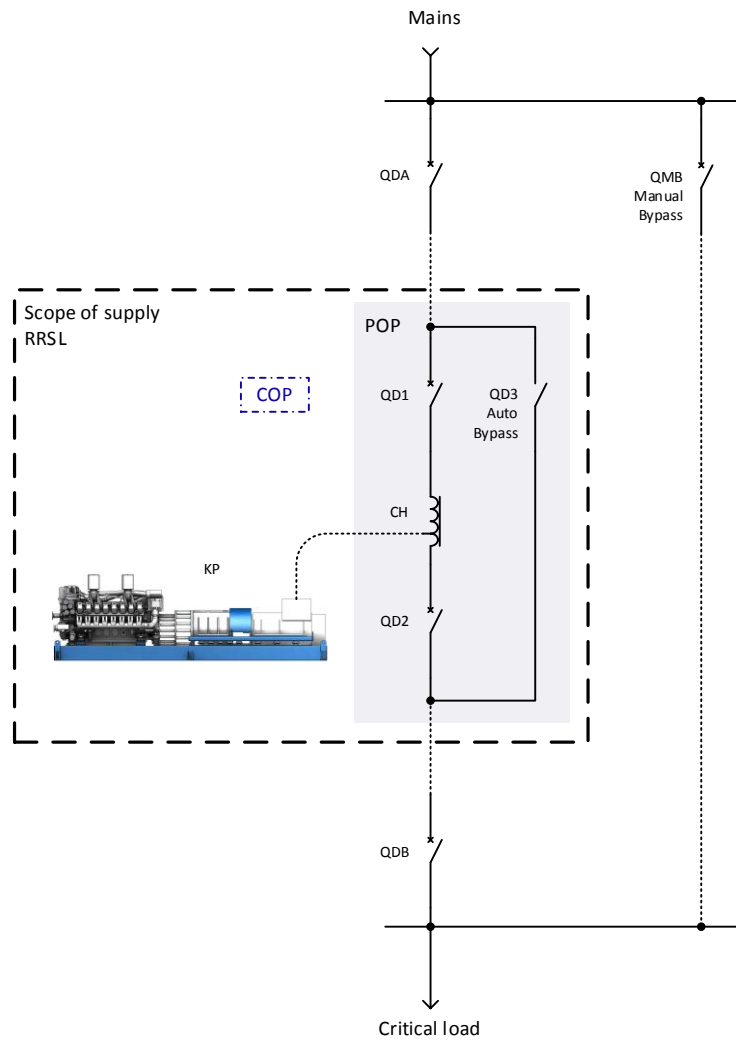

## 9 ELECTRICAL PERFORMANCES

### 9.1 Acceptable mains tolerance in conditioning mode

Characteristics	Value
Frequency tolerance (Permanent)	$\pm 0.4$ Hz
Voltage tolerance (Permanent)	$\pm 10$ %

### 9.2 Voltage regulation (conditioning and independent mode)

Conditions	Value
In steady state conditions	$\pm 1$ %
For load variation of 10%	$\pm 1$ %
For load variation of 50%	$\pm 5$ %
On mains failure at 100% load	$\pm 5$ %

### 9.3 Frequency regulation in independent mode

Conditions	Value
In steady state conditions	$\pm 0.2$ %
For load variation of 10%	$\pm 0.5$ %
For load variation of 50%	$\pm 1$ Hz
On mains failure at 100% load	$\pm 1$ Hz

### 9.4 Harmonics

Characteristics	Value
Total harmonic distortion (THD) on linear load	$\leq 3$ %

### 9.5 Phase angle

Conditions	Value
With balanced load	$120^\circ \pm 0^\circ$
With 25 % unbalanced load	$120^\circ \pm 1^\circ$

NOTE:

- Typical values.